



actual size

Automotive SMD Crystal · JXS53P4

4 Pad Version · 5.0 x 3.2 mm

- seam sealed ceramic/metal package
- all versions are AEC-Q200 qualified
- HMR version with extended shock & vibration immunity
- reflow soldering temperature: 260 °C max.



General Data

type	JXS53P4
frequency range	8.0 ~ 56.0 MHz (fund. AT-cut)
frequency tolerance at 25 °C	± 10 ppm, ± 30 ppm, ± 50 ppm
load capacitance C_L	12 pF standard (option: 8 pF ~ 30.0 pF / series)
shunt capacitance C_0	< 7 pF
storage temperature	-40 °C ~ +125 °C
shock resistance	> 100 g (half sine pulse, 6.0 ms)*
drive level max.	100 μ W (10 μ W recommended)
aging	< ± 3 ppm first year

* optional HMR version: 3000G / half sine pulse / 0.3 ms

ESR (series resistance R_s) at max. temp. range

frequency in MHz	vibration mode	ESR max. in Ω	ESR typ. in Ω
8.0 ~ 9.999	fund.-AT	100	50
10.0 ~ 10.999	fund.-AT	50	30
11.0 ~ 11.999	fund.-AT	40	25
12.0 ~ 21.999	fund.-AT	40	20
22.0 ~ 24.999	fund.-AT	40	15
25.0 ~ 49.999	fund.-AT	30	15
50.0 ~ 56.000	fund.-AT	40	20

Frequency Stability vs. Temperature

		± 15 ppm	± 20 ppm	± 30 ppm	± 50 ppm	± 100 ppm
-20 °C ~ +70 °C	STD.	○	○	○	○	○
-40 °C ~ +85 °C	T1	○	○	○	○	○
-40 °C ~ +105 °C	T2				○	○
-40 °C ~ +125 °C	T3					○

○ available

Marking

frequency with load capacitance code
company code / date code / internal code

date code: year/month
example: 2A = 2012 January

Jan.	Febr.	Mar.	Apr.	May	June
A	B	C	D	E	F

July	Aug.	Sept.	Oct.	Nov.	Dec.
G	H	J	K	L	M

Dimensions

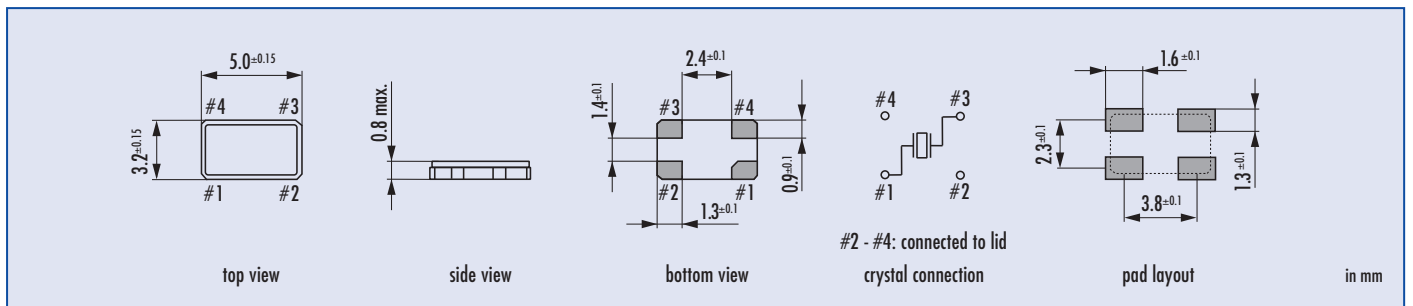

Order Information

Q	frequency	type	load capacitance	stability at 25 °C	stability vs. temp. range	option 1	option 2
Quartz	8.0 ~ 56.0 MHz	JXS53P4	12 pF standard 8 pF ~ 30 pF S for series	10 = ± 10 ppm 30 = ± 30 ppm 50 = ± 50 ppm	15 = ± 15 ppm 20 = ± 20 ppm 30 = ± 30 ppm 50 = ± 50 ppm 100 = ± 100 ppm	blank = -20 °C ~ +70 °C T1 = -40 °C ~ +85 °C T2 = -40 °C ~ +105 °C T3 = -40 °C ~ +125 °C FU = for fundamental frequencies ≥ 20 MHz	AEC = AEC-Q200 qualified HMR = high mechanical reliability (3000g/half sine wave/0.3ms)

Example: Q 30.0-JXS53P4-12-30/50-FU-AEC-LF (Suffix LF = RoHS compliant / Pb free pads)

