

SMD Communication Crystal

Low profile SMD AT-cut quartz crystal in a ceramic package with a 1.6 x 1.2 mm foot print.



Product description

Miniature low profile AT-cut quartz crystal. True SMD style, ceramic package with nickel plated lid, seam welded. The product is supplied on tape and reel.

Applications

- Automotive
- Communications
- GPS
- Consumer
- Feature phone

Features

- Low aging
- Wide temperature range
- Low hysteresis

Specifications

1.0 SPECIFICATION REFERENCE

Line	Parameter	Description
1.1	Model description	RSX1612
1.2	RoHS compliant	Yes
1.3	Reference number	
1.4	Rakon part number	
1.5	Package	W, M, or V

2.0 FREQUENCY CHARACTERISTICS

Line	Parameter	Test Condition	Value	Unit
2.1	Frequency		26 to 52	MHz
2.2	Calibration tolerance	Frequency at 25°C ±2°C and specified load capacitance	±10 to 50	ppm
2.3	Reflow shift	Frequency shift after reflow with 4 hours recovery at 25°C	±1 max	ppm
2.4	Frequency stability over temperature	Referenced to frequency reading at 25°C and the specified load capacitance	±15 to 50	ppm
2.5	Temperature range	Operating temperature	-40 to 85	°C
2.6	Frequency perturbations	Residual error from the frequency versus temperature 5th order polynomial curve fit. Minimum of 1 frequency reading every 3°C over operating temperature range	1 max	ppm
2.7	g sensitivity	Gamma vector of all three axes from 30 Hz to 1500 Hz	2 max	ppb/g
2.8	Long term stability	Frequency drift over 1 year at 25°C	±1 max	ppm

3.0 ELECTRICAL

Line	Parameter	Test Condition	Value	Unit
3.1	Load capacitance (CL)	Frequency is calibrated at room temperature	5 to 32	pF
3.2	Shunt capacitance (C0)		0.5 to 3	pF
3.3	Pullability		0.5 min	ppm/pF
3.4	Drive level		30 max	μW
3.5	Equivalent series resistance (ESR)		85 max	Ω
3.6	Insulation resistance (IR)	100V ±15V at 25°C	500 min	MΩ

4.0 ENVIRONMENTAL

Line	Parameter	Description
4.1	Shock	Half sine-wave acceleration of 3000g peak amplitude. Duration: 0.3ms, Velocity: 12.3ft/s [MIL-STD-202 Method 213]
4.2	Moisture resistance	1000 hours at 85°C, 85% Relative Humidity. Biased. [MIL-STD-202 Method 106G]
4.3	Temperature cycling	1000 temperature cycles, where each cycle consists of a 25 minute soak time at -45°C followed by a 25 minute soak time at 85°C, with a 60 second maximum transition time between temperatures. Air to air transition. [JESD22 Method-104C]
4.4	Vibration	5g's for 20 minimum, 12 cycles in each of 3 orientations. Tested from 10-2000 Hz [MIL-STD-202 Method 204]
4.5	Storage temperature	-40 to 85°C

5.0 MANUFACTURING INFORMATION

Line	Parameter	Description
5.1	Washing	Able to withstand aqueous washing processes
5.2	Reflow	Able to withstand forced convection reflow process. Refer to Pb-free Reflow drawing
5.3	Packaging description	Tape and reel. Standard packing quantity is 3000 units per ø180 mm reel.

6.0 PIN CONNECTIONS

Line	Parameter	Description
6.1	Pin 1	Crystal
6.2	Pin 2	GND
6.3	Pin 3	Crystal
6.4	Pin 4	GND (NC for package M)

7.0 MARKING

Line	Parameter	Description
7.1	Type	Laser engraved
7.2	Line 1	R and [XX.XX] frequency in MHz
7.3	Line 2	Pin 1 and date code

Drawing Name: RSX1612 Model (Package W, M & V)

MODEL DRAWING

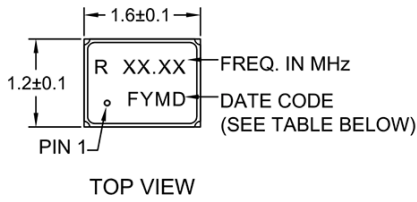

NOTE:

1. MARKING INFORMATION IS DETAILED IN THE SPECIFICATION.
2. PIN CONNECTIONS ARE DETAILED IN THE SPECIFICATION.

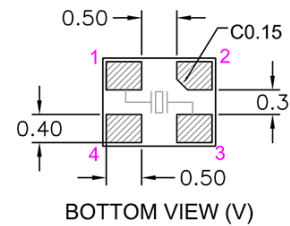
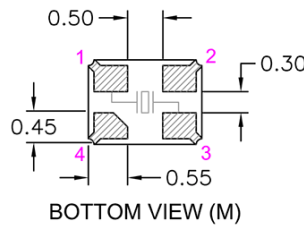
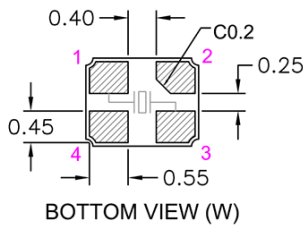
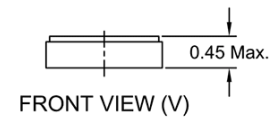
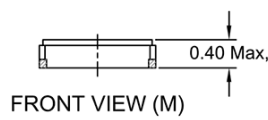
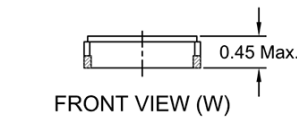

RECOMMENDED PAD LAYOUT - TOP VIEW

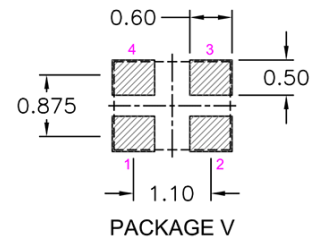
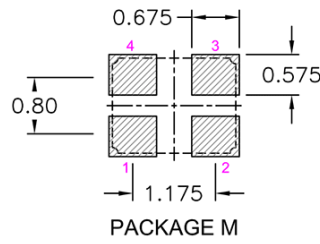
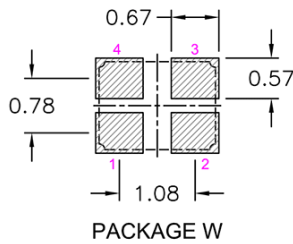

Y - Year Code

Code	Year	Code	Year
A	2010	N	2023
B	2011	O	2024
C	2012	P	2025
D	2013	Q	2026
E	2014	R	2027
F	2015	S	2028
G	2016	T	2029
H	2017	U	2030
I	2018	V	2031
J	2019	W	2032
K	2020	X	2033
L	2021	Y	2034
M	2022	Z	2035

M - Month Code

Code	Month
1	Jan
2	Feb
3	Mar
4	Apr
5	May
6	Jun
7	Jul
8	Aug
9	Sep
A	Oct
B	Nov
C	Dec

D - Day Code

Code	Day	Code	Day	Code	Day
1	1	E	14	R	27
2	2	F	15	S	28
3	3	G	16	T	29
4	4	H	17	U	30
5	5	I	18	V	31
6	6	J	19		
7	7	K	20		
8	8	L	21		
9	9	M	22		
A	10	N	23		
B	11	O	24		
C	12	P	25		
D	13	Q	26		

TITLE: RSX1612 Model (Package W, M & V)

RELATED DRAWINGS:

FILENAME: CAT785

REVISION: B

DATE: 26-Apr-13

SCALE: 10 : 1

Millimetres

TOLERANCES:

XX =
X.X = ±0.1
X.XX = ±0.10
X.XXX = ±0.05
X° =
Hole =

rakon

© 2013 Rakon Limited

Drawing Name: RSX1612 Tape & Reel (Package W)

TAPE DETAIL (Scale 5 : 1)

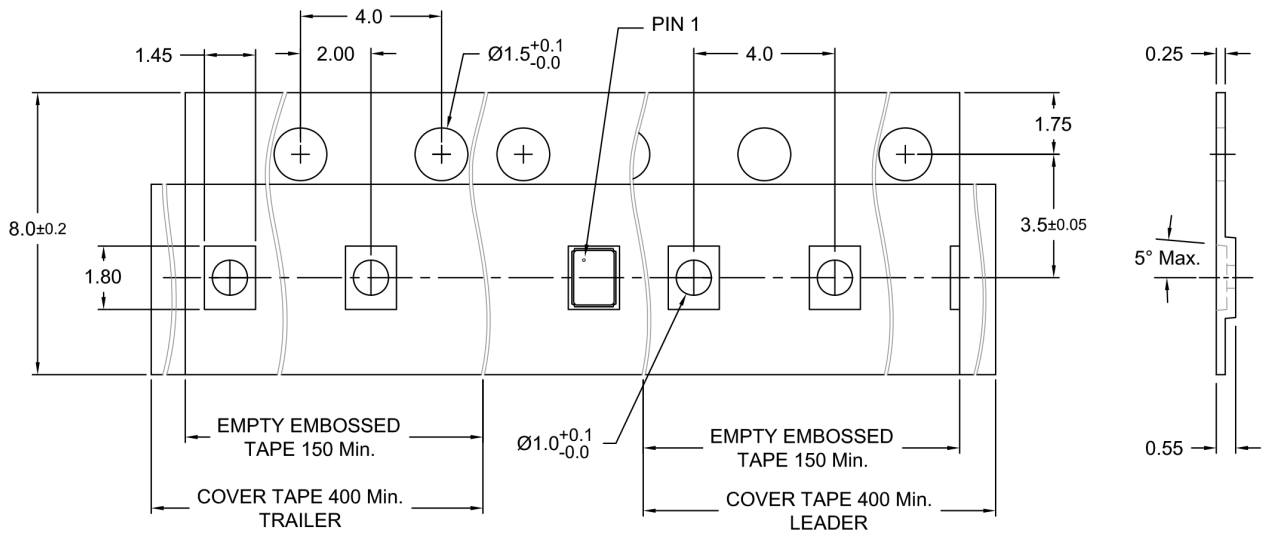

REEL DETAIL (Scale 1 : 2.5)

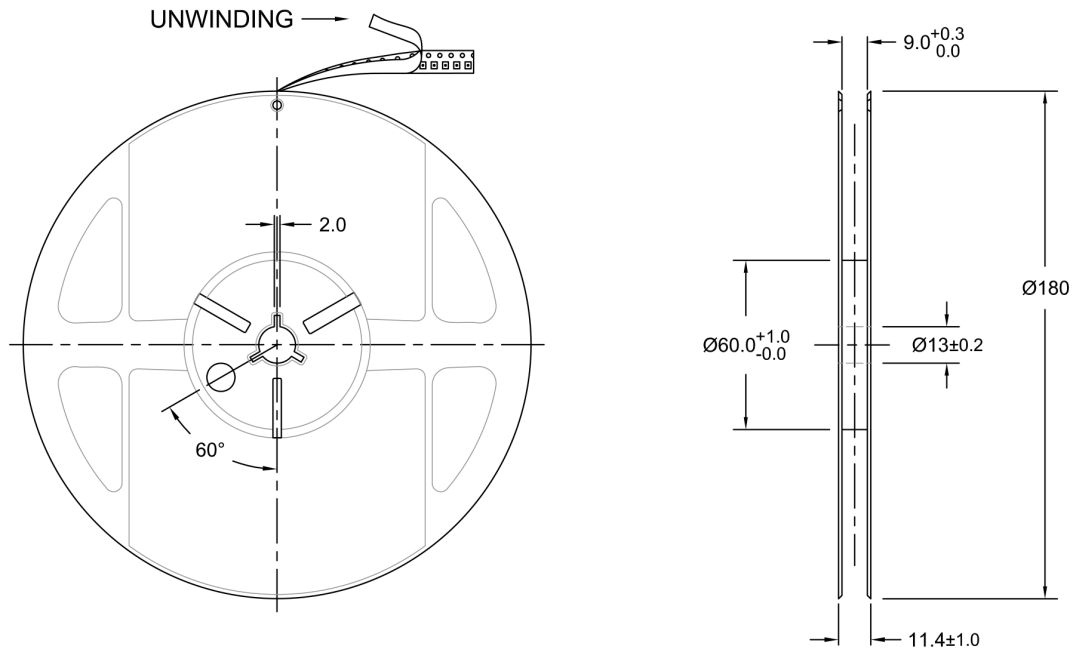

TITLE: 1612 SERIES CRYSTAL TAPE & REEL (Package W)

FILENAME: CAT786

TOLERANCES:

RELATED DRAWINGS:

REVISION: A

XX =

DATE: 21-Mar-13

X.X = ±0.1

SCALE: 5 : 1

X.XX = ±0.05

Millimetres

X.XXX =

X° =

Hole =

rakon

© 2013 Rakon Limited

Drawing Name: RSX1612 Tape & Reel (Package M)

TAPE DETAIL (Scale 5 : 1)

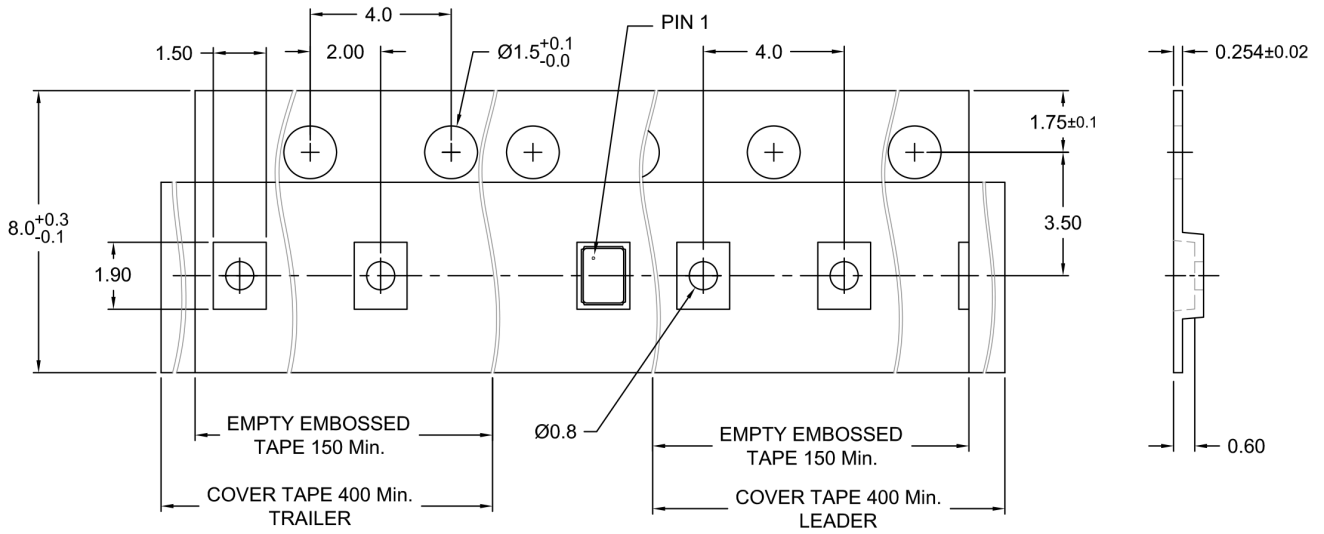

REEL DETAIL (Scale 1 : 2.5)

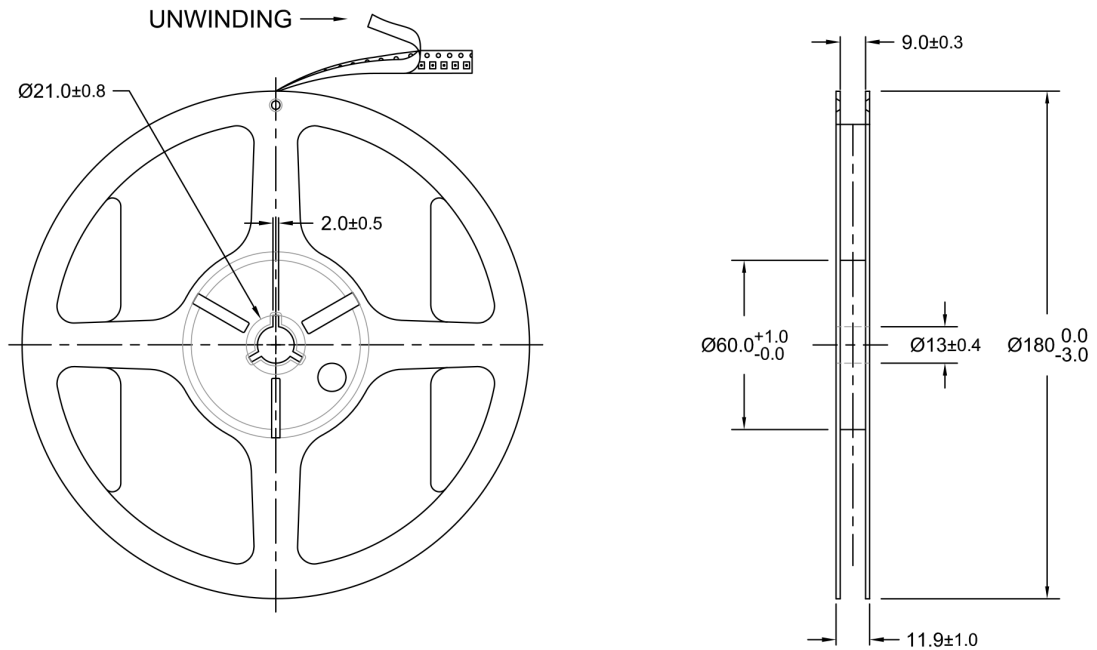

TITLE: 1612 SERIES CRYSTAL TAPE & REEL (Package M)

RELATED DRAWINGS:

FILENAME: CAT788

REVISION: A

DATE: 21-Mar-13

SCALE: 5 : 1

Millimetres

TOLERANCES:

XX =
 X.X = ± 0.1
 X.XX = ± 0.05
 X.XXX =
 X° =
 Hole =

rakon

© 2013 Rakon Limited

Drawing Name: RSX1612 Tape & Reel (Package V)

TAPE DETAIL (Scale 5 : 1)

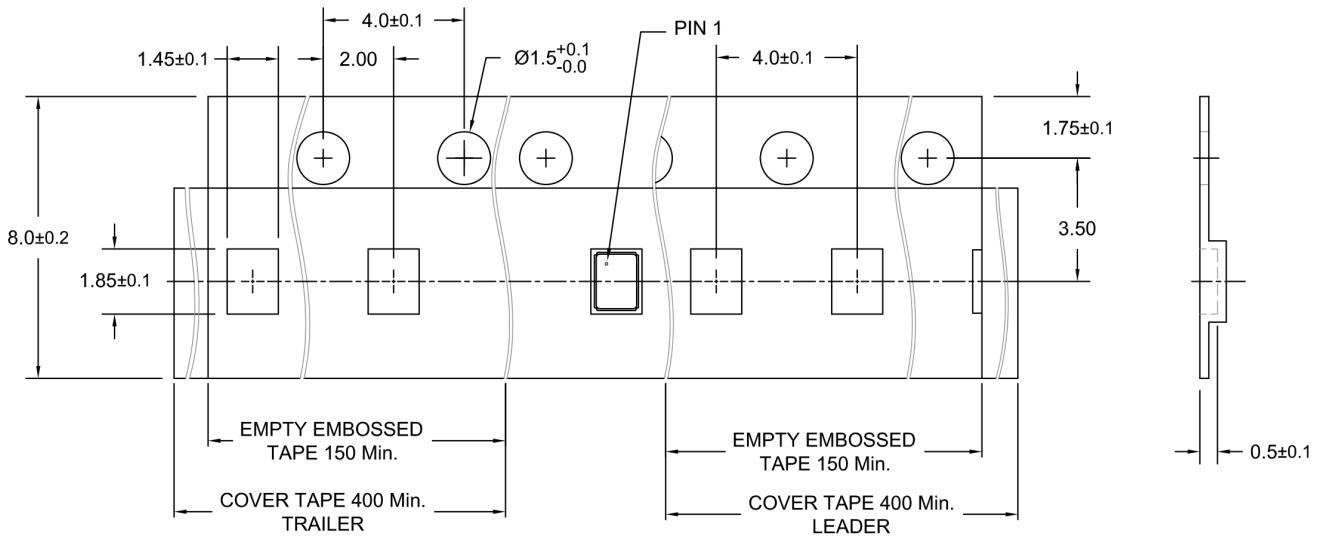

REEL DETAIL (Scale 1 : 2.5)

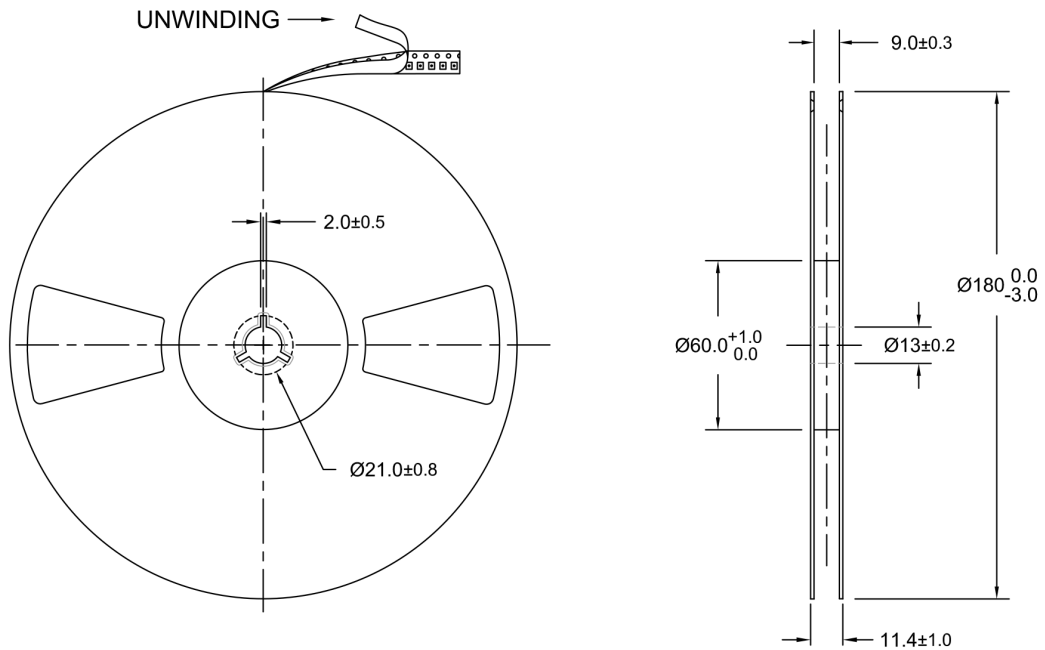

TITLE: 1612 SERIES CRYSTAL TAPE & REEL (Package V)

RELATED DRAWINGS:

FILENAME: CAT787

REVISION: A

DATE: 21-Mar-13

SCALE: 5 : 1

Millimetres

TOLERANCES:

XX =

X.X = ±0.1

X.XX = ±0.05

X.XXX =

X° =

Hole =

rakon

© 2013 Rakon Limited

Drawing Name: RSX/RGX Crystals Pb-free Reflow

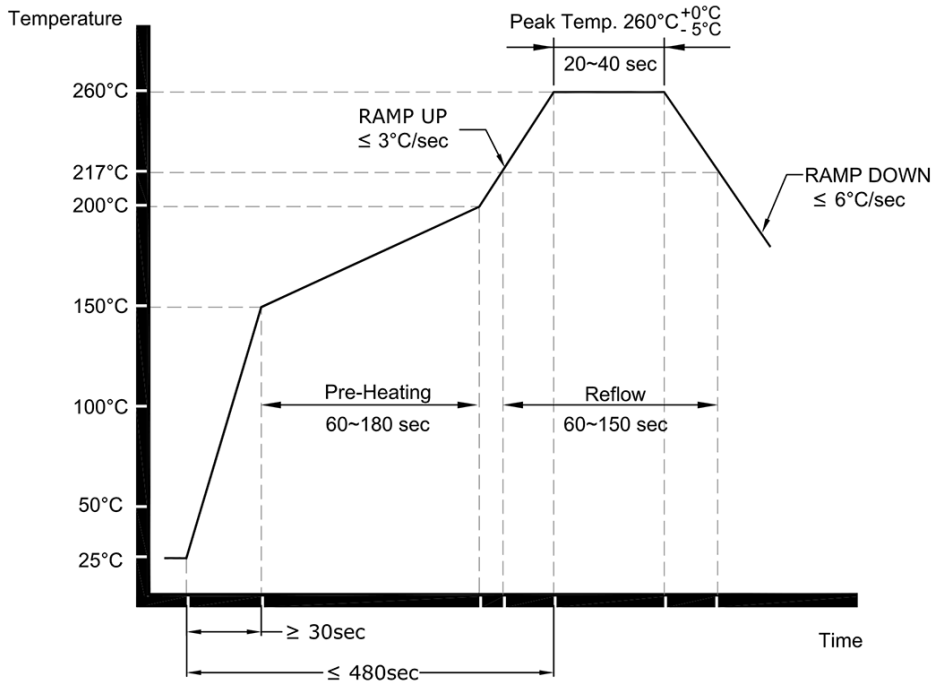

NOTE:

The product has been tested to withstand the Reflow Profile shown. The Reflow Profile used to solder Rakon RSX/RGX crystals are determined by the solder paste Manufacturer's specification. It is recommended that the Reflow Profile used does not exceed the one shown above.

TITLE: CRYSTAL Pb-FREE REFLOW

RELATED DRAWINGS:

FILENAME: CAT353

REVISION: B

DATE: 01-Feb-07

SCALE: NTS

Millimetres

rakon

© 2009 Rakon Limited