

Model 655

Ultra Low Jitter LVPECL or LVDS Clock

Features

- Ceramic Surface Mount Package
- Ultra Low Phase Jitter Performance, 100fs Typical
- Fundamental or 3rd Overtone Crystal Design
- Frequency Range 80 – 170MHz *
- +2.5V or +3.3V Operation
- Output Enable Standard
- Tape and Reel Packaging, EIA-418

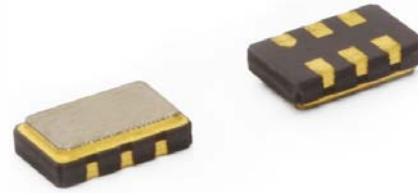

Part Dimensions:
5.0 × 3.2 × 1.2mm • 62.00mg

Applications

- SerDes
- Storage Area Networking
- Broadband Access
- SONET/SDH/DWDM
- PON
- Ethernet/GbE/SyncE
- Fiber Channel
- Test and Measurement

Standard Frequencies, 100fs Maximum

- 125.00MHz
- 156.25MHz
- 155.52MHz
- 161.1328MHz

* Check with factory for availability.

Description

CTS Model 655 is a low cost, high performance clock oscillator supporting differential LVPECL or LVDS outputs. Employing the latest IC technology, M655 has excellent stability and very low jitter/phase noise performance.

Ordering Information

Model	Output Type	Frequency Code [MHz]	Frequency Stability	Temperature Range	Supply Voltage	Packaging																										
655	P	XXX or XXXX	3	I	3	T																										
	<table border="1"> <thead> <tr> <th>Code</th> <th>Output</th> </tr> </thead> <tbody> <tr> <td>P</td> <td>LVPECL - Pin 1 Enable</td> </tr> <tr> <td>L</td> <td>LVDS - Pin 1 Enable</td> </tr> <tr> <td>E</td> <td>LVPECL - Pin 2 Enable</td> </tr> <tr> <td>V</td> <td>LVDS - Pin 2 Enable</td> </tr> </tbody> </table>	Code	Output	P	LVPECL - Pin 1 Enable	L	LVDS - Pin 1 Enable	E	LVPECL - Pin 2 Enable	V	LVDS - Pin 2 Enable		<table border="1"> <thead> <tr> <th>Code</th> <th>Stability</th> </tr> </thead> <tbody> <tr> <td>6</td> <td>±20ppm²</td> </tr> <tr> <td>5</td> <td>±25ppm</td> </tr> <tr> <td>3</td> <td>±50ppm</td> </tr> <tr> <td>2</td> <td>±100ppm</td> </tr> </tbody> </table>	Code	Stability	6	±20ppm ²	5	±25ppm	3	±50ppm	2	±100ppm		<table border="1"> <thead> <tr> <th>Code</th> <th>Voltage</th> </tr> </thead> <tbody> <tr> <td>2</td> <td>+2.5Vdc</td> </tr> <tr> <td>3</td> <td>+3.3Vdc</td> </tr> </tbody> </table>	Code	Voltage	2	+2.5Vdc	3	+3.3Vdc	
Code	Output																															
P	LVPECL - Pin 1 Enable																															
L	LVDS - Pin 1 Enable																															
E	LVPECL - Pin 2 Enable																															
V	LVDS - Pin 2 Enable																															
Code	Stability																															
6	±20ppm ²																															
5	±25ppm																															
3	±50ppm																															
2	±100ppm																															
Code	Voltage																															
2	+2.5Vdc																															
3	+3.3Vdc																															
		<table border="1"> <thead> <tr> <th>Code</th> <th>Frequency</th> </tr> </thead> <tbody> <tr> <td></td> <td>Product Frequency Code¹</td> </tr> </tbody> </table>	Code	Frequency		Product Frequency Code ¹		<table border="1"> <thead> <tr> <th>Code</th> <th>Temp. Range</th> </tr> </thead> <tbody> <tr> <td>A</td> <td>-10°C to +60°C</td> </tr> <tr> <td>C</td> <td>-20°C to +70°C</td> </tr> <tr> <td>I</td> <td>-40°C to +85°C</td> </tr> </tbody> </table>	Code	Temp. Range	A	-10°C to +60°C	C	-20°C to +70°C	I	-40°C to +85°C	<table border="1"> <thead> <tr> <th>Code</th> <th>Packing</th> </tr> </thead> <tbody> <tr> <td>T</td> <td>1k pcs./reel</td> </tr> </tbody> </table>	Code	Packing	T	1k pcs./reel											
Code	Frequency																															
	Product Frequency Code ¹																															
Code	Temp. Range																															
A	-10°C to +60°C																															
C	-20°C to +70°C																															
I	-40°C to +85°C																															
Code	Packing																															
T	1k pcs./reel																															

Notes:

- 1] Refer to document 016-1454-0, Frequency Code Tables. 3-digits for frequencies <100MHz, 4-digits for frequencies 100MHz or greater.
- 2] Consult factory for availability of 6I Stability/Temperature combination.

Not all performance combinations and frequencies may be available.
Contact your local CTS Representative or CTS Customer Service for availability.

Electrical Specifications

Operating Conditions

PARAMETER	SYMBOL	CONDITIONS	MIN	TYP	MAX	UNIT
Maximum Supply Voltage	V_{CC}	-	-0.5	-	5.0	V
Supply Voltage	V_{CC}	$\pm 5\%$	2.375 3.135	2.5 3.3	2.625 3.465	V
Supply Current						
LVPECL	I_{CC}	Maximum Load	-	55	88	mA
LVDS			-	45	66	
Operating Temperature	T_A	-	-20 -40	+25	+70 +85	$^{\circ}\text{C}$
Storage Temperature	T_{STG}	-	-40	-	+125	$^{\circ}\text{C}$

Frequency Stability

PARAMETER	SYMBOL	CONDITIONS	MIN	TYP	MAX	UNIT
Frequency Range						
LVPECL	f_0	-		80 - 170		MHz
LVDS				80 - 170		
Frequency Stability [Note 1]	$\Delta f/f_0$	-		20, 25, 50 or 100		\pm ppm
Aging	$\Delta f/f_{25}$	First Year @ +25 $^{\circ}\text{C}$, nominal V_{CC}	-3	-	3	ppm

1.] Inclusive of initial tolerance at time of shipment, changes in supply voltage, load, temperature and 1st year aging.

Output Parameters

PARAMETER	SYMBOL	CONDITIONS	MIN	TYP	MAX	UNIT
Output Type	-	-		LVPECL		-
Output Load	R_L	Terminated to $V_{CC} - 2.0\text{V}$	-	50	-	Ohms
Output Voltage Levels						
	V_{OH}	PECL Load, -20 $^{\circ}\text{C}$ to +70 $^{\circ}\text{C}$	$V_{CC} - 1.025$	-	$V_{CC} - 0.880$	V
	V_{OL}		$V_{CC} - 1.810$	-	$V_{CC} - 1.620$	
	V_{OH}	PECL Load, -40 $^{\circ}\text{C}$ to +85 $^{\circ}\text{C}$	$V_{CC} - 1.085$	-	$V_{CC} - 0.880$	V
	V_{OL}		$V_{CC} - 1.830$	-	$V_{CC} - 1.555$	
Output Duty Cycle	SYM	@ $V_{CC} - 1.3\text{V}$	45	-	55	%
Rise and Fall Time	T_R, T_F	@ 20%/80% Levels, $R_L = 50$ Ohms	-	0.3	0.7	ns
Output Type	-	-		LVDS		-
Output Load	R_L	Between Outputs	-	100	-	Ohms
Output Voltage Levels						
	V_{OH}	LVDS Load	-	1.43	1.60	V
	V_{OL}		0.90	1.10	-	
Output Duty Cycle	SYM	@ 1.25V	45	-	55	%
Differential Output Voltage	V_{OD}	$R_L = 100$ Ohms	247	330	454	mV
Offset Voltage	V_{OS}	LVDS Load	1.125	1.25	1.375	V
Rise and Fall Time	T_R, T_F	@ 20%/80% Levels, $R_L = 100$ Ohms	-	0.4	0.7	ns

Electrical Specifications

Output Parameters

PARAMETER	SYMBOL	CONDITIONS	MIN	TYP	MAX	UNIT
Start Up Time	T_S	Application of V_{CC}	-	2	5	ms
Enable Function [Standby]						
Enable Input Voltage	V_{IH}	Pin 1 or 2 Logic '1', Output Enabled	$0.7V_{CC}$	-	-	V
Disable Input Voltage	V_{IL}	Pin 1 or 2 Logic '0', Output Disabled	-	-	$0.3V_{CC}$	V
Disable Time	T_{PLZ}	Pin 1 or 2 Logic '0', Output Disabled	-	-	200	ns
Enable Time	T_{PLZ}	Pin 1 or 2 Logic '1', Output Enabled	-	-	2	ms
Phase Jitter, RMS	t_{jrms}	80 - 124.9MHz, Bandwidth 12 kHz - 20 MHz	-	-	200	fs
		125 - 170MHz, Bandwidth 12 kHz - 20 MHz	-	-	100	fs
Period Jitter, pk-pk	p_{jpk-pk}	-	-	2.6	-	ps
Period Jitter, RMS	p_{jrms}	-	-	25	-	ps

Enable Truth Table

Pin 1 or Pin 2	Pin 4 & Pin 5
Logic '1'	Output
Open	Output
Logic '0'	High Imp.

Test Circuit

LVPECL

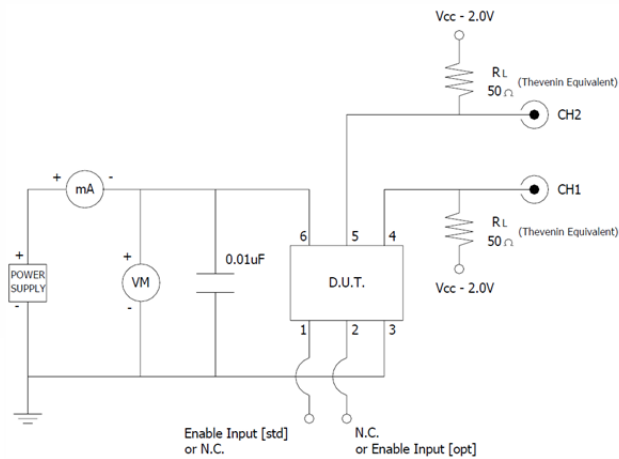

LVDS

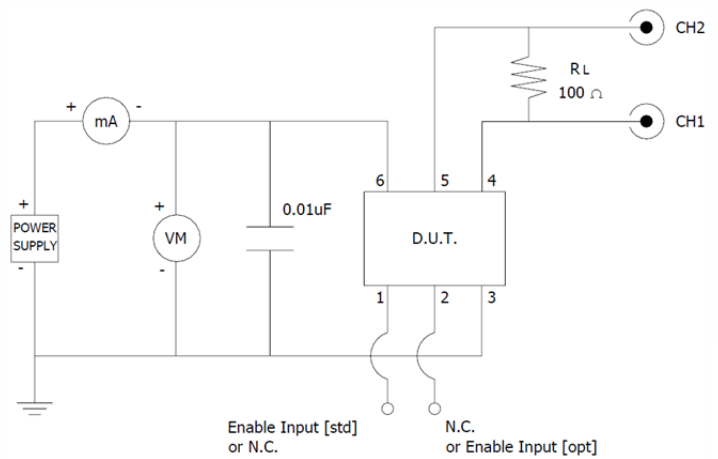

Output Waveform

LVPECL or LVDS

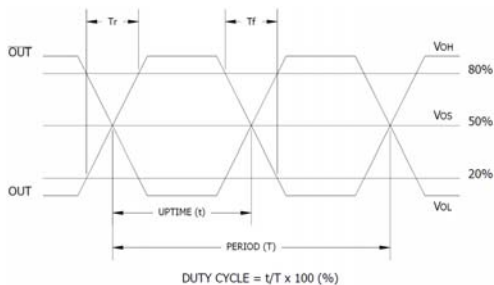

Electrical Specifications

Performance Data

Phase Noise [typical]

125.00MHz, LVPECL, $V_{CC} = 3.3V$, $T_A = +25^\circ C$

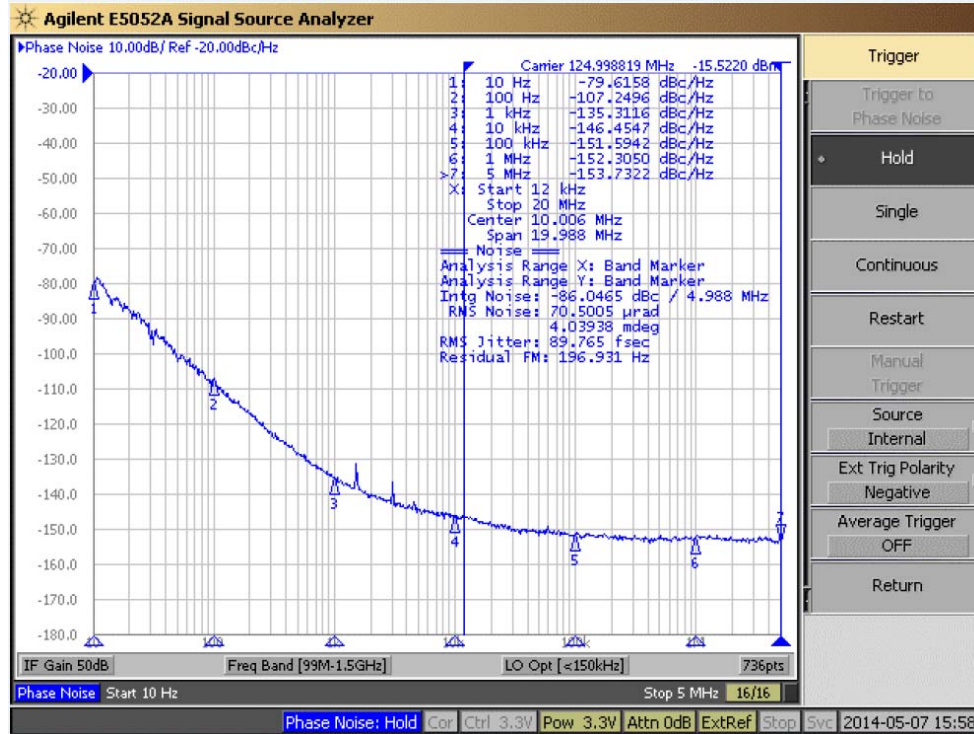

156.25MHz, LVPECL, $V_{CC} = 3.3V$, $T_A = +25^\circ C$

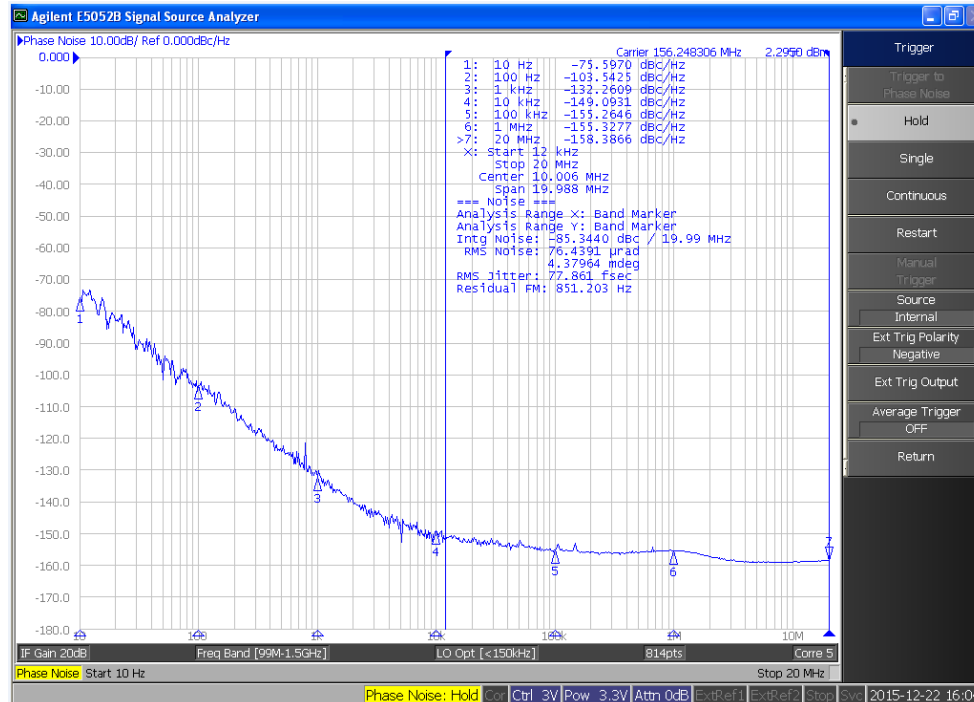

Electrical Specifications

Performance Data

Phase Noise [typical]

156.25MHz, LVDS, $V_{CC} = 3.3V$, $T_A = +25^\circ C$

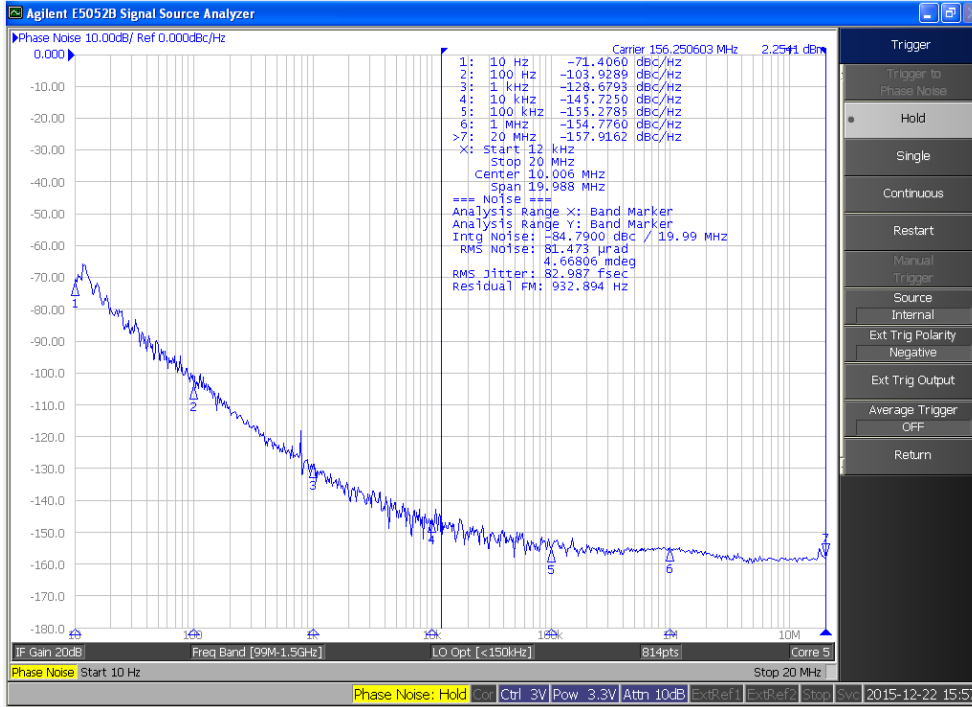

Phase Noise Tabulated

Typical, $V_{CC} = 3.3V$, $T_A = +25^\circ C$

PARAMETER	SYMBOL	CONDITIONS	TYP	UNIT
LVPECL @ 125.00MHz				
Phase Noise		Single Side Band		
		@ 10Hz	-79.62	
		@ 100Hz	-107.25	
		@ 1kHz	-135.31	dBc/Hz
		@ 10kHz	-146.45	
		@ 100kHz	-151.59	
		@ 1MHz	-152.31	
		@ 5MHz	-153.73	
Phase Jitter, RMS	tjrms	Integration Bandwidth 12kHz - 20MHz	89.77	fs

PARAMETER	SYMBOL	CONDITIONS	TYP	UNIT
LVPECL @ 156.25MHz				
Phase Noise		Single Side Band		
		@ 10Hz	-75.60	
		@ 100Hz	-103.54	
		@ 1kHz	-132.26	dBc/Hz
		@ 10kHz	-149.09	
		@ 100kHz	-155.26	
		@ 1MHz	-155.33	
		@ 20MHz	-158.39	
Phase Jitter, RMS	tjrms	Integration Bandwidth 12kHz - 20MHz	77.86	fs

PARAMETER	SYMBOL	CONDITIONS	TYP	UNIT
LVDS @ 156.25MHz				
Phase Noise		Single Side Band		
		@ 10Hz	-71.41	
		@ 100Hz	-103.93	
		@ 1kHz	-128.68	dBc/Hz
		@ 10kHz	-145.73	
		@ 100kHz	-155.28	
		@ 1MHz	-154.78	
		@ 20MHz	-157.92	
Phase Jitter, RMS	tjrms	Integration Bandwidth 12kHz - 20MHz	82.99	fs

Mechanical Specifications

Package Drawing

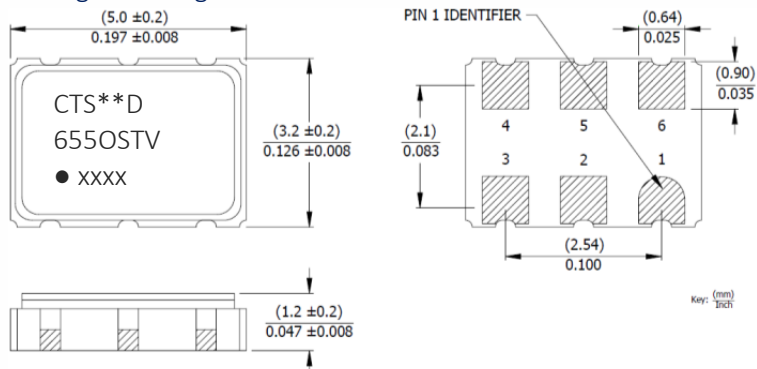

Marking Information

- ** - Manufacturing Site Code.
- D - Date Code. See Table I for codes.
- O - Output Type; P or E = LVPECL, L or V = LVDS.
[Refer to Ordering Information]
- V - Voltage Code; 3 = 3.3V, 2 = 2.5V.
- xxxx - Frequency Code.
3-digits, frequencies below 100MHz
4-digits, frequencies 100MHz or greater
[See document 016-1454-0, Frequency Code Tables.]

Recommended Pad Layout

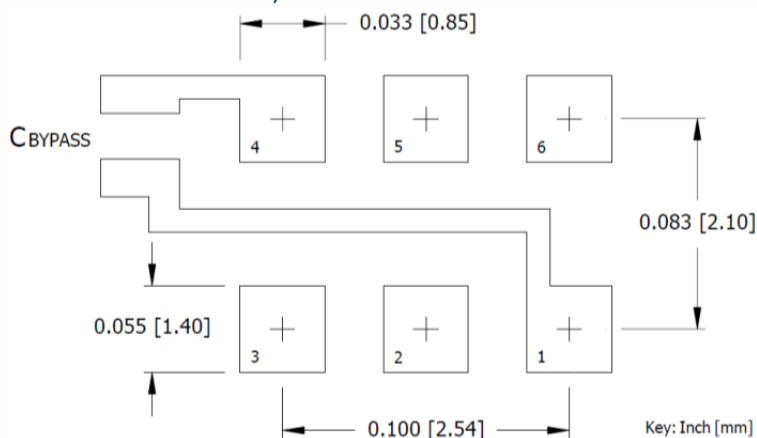

Notes

- JEDEC termination code (e4). Barrier-plating is nickel [Ni] with gold [Au] flash plate.
- Reflow conditions per JEDEC J-STD-020; +260°C maximum, 20 seconds.
- MSL = 1.

Pin Assignments

Pin	Symbol	Function
1	EOH or N.C.	Enable [std] or No Connect
2	N.C. or EOH	No Connect or Enable [opt]
3	GND	Circuit & Package Ground
4	Output	RF Output
5	Output	Complimentary RF Output
6	V _{CC}	Supply Voltage

Table I - Date Code

YEAR		MONTH														
		JAN	FEB	MAR	APR	MAY	JUN	JUL	AUG	SEP	OCT	NOV	DEC			
2001	2005	2009	2013	2017	A	B	C	D	E	F	G	H	J	K	L	M
2002	2006	2010	2014	2018	N	P	Q	R	S	T	U	V	W	X	Y	Z
2003	2007	2011	2015	2019	a	b	c	d	e	f	g	h	j	k	l	m
2004	2008	2012	2016	2020	n	p	q	r	s	t	u	v	w	x	y	z

Packaging - Tape and Reel

Tape Drawing

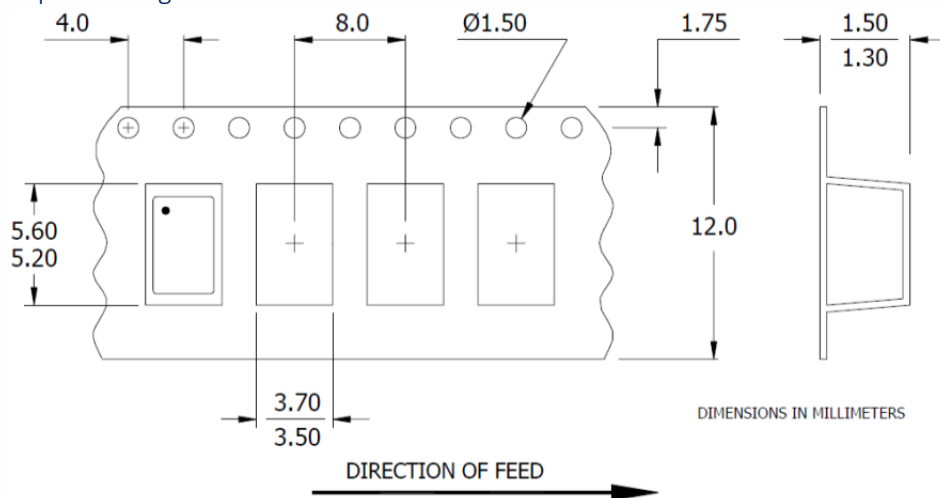

Reel Drawing

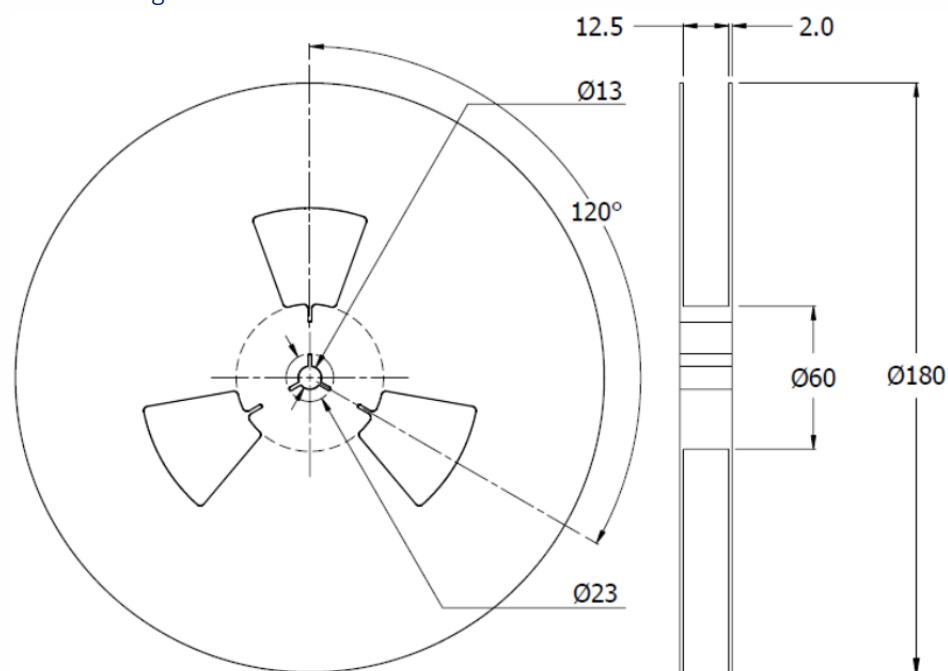

Notes

1. Device quantity is 1k pieces per 180mm reel.
2. Complete CTS part number, frequency value and date code information must appear on reel and carton labels.